

0.8t → 6.3t

V LEVER

VR2

VITAL
LEVER

Lever hoists

Light Weight, High Quality!

For plated parts,
we use
trivalent chromate
treatment,
which is
environment friendly.



Lifting



Lowering



Fastening



Pulling



VITAL brand is registered worldwide.

For Lifting, Lowering, Fastening and Pulling.

VITAL[®]
LEVER

Lever hoists

V LEVER VR2

Idling operation:

1. Depress the retaining pawl all the way down and pull the grip ring towards you.
2. The chain can be adjusted up and down by hand.
3. To terminate the idling, set the change lever in the down (↓) position. (See diagram at right).

Then, depressing the retaining pawl as far as possible, push the grip ring gently so as to let the pawl engage the outer edge of the retaining plate.

Next, grip the grip ring and handle with a single hand and push them while turning them counterclockwise.

The retaining pawl returns to its original position.

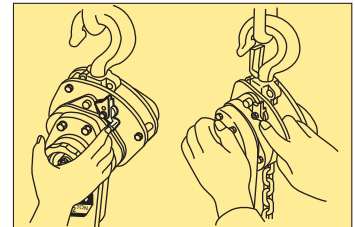

0.8 t



1 t



1.6 t



3.2 t



6.3 t

Specifications

Model Number	VR2-08	VR2-10	VR2-15	VR2-30	VR2-60	
Capacity (t)	0.8	1	1.6	3.2	6.3	
Standard Lift (m)	1.5	1.5	1.5	1.5	1.5	
Net Weight (kg)	6.9	7.1	9.7	16.3	26.7	
Min. Distance between Hooks (mm)	295	310	335	405	550	
Pull Required to Lift Full Load	(kgf)	15	20	18	38	39
	(N)	147	196	177	373	382
Chain thickness (mm)	6.3	6.3	7.1	9.0	9.0	
Dimension	a (mm)	148	148	163.5	191	191
	b (mm)	128	128	148	181	244
	c (mm)	295	310	325	395	550
	d (mm)	256	256	368	368	368
	e (mm)	27	30	34	43	47

* Hoists with the life in other lengths are also available.

* Please note that the specifications on this leaflet may be modified for improvements without notice.

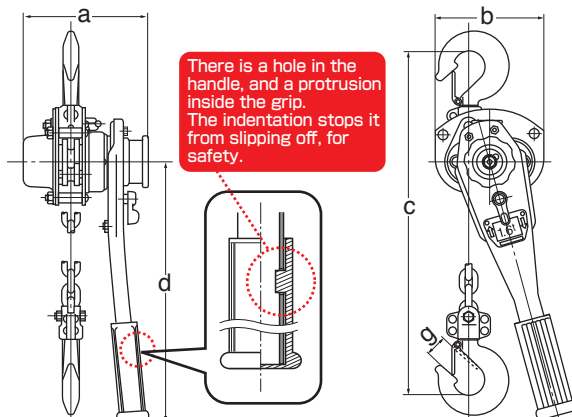

Vital offers products that are designed for longtime use, providing the lowest possible per-use cost.

Since 1933

VITAL CHAIN BLOCK MFG.CO.,LTD.