

VITAL[®]

**NICE POWER!
NICE LEVER!**



For plated parts,
we use
trivalent chromate
treatment,
which is
environment friendly.

Patented Device

VITAL brand is registered worldwide.

0.25t → 9t NICE LEVER NR2

Automatic free pulley
requires no special
release operation.
Greatly improves
work efficiency!
The best you'll find.

**Nice Lever offers following
exceptional features!**

1. Automatic switching to free pulley mode.

Simply remove the load from the bottom hook and pull the chain to automatically switch to free pulley mode. The winch automatically switches back to normal mode when a load is placed on the bottom hook. Automatic switching greatly improves work efficiency.

2. Easy maintenance.

The free pulley mechanism has only a few parts, making disassembly and repair a quick and easy process.

3. Plated chain.

The winch chain is tough-pitch plated to prevent rusting and ensure continuous smooth operation.

4. Locked chain release mechanism.

If the chain locks due to an impacting load, simply move the lever by hand to release the chain.

5. Knobbed hook.

The winch hook is equipped with an anti-slip knob. Even if the hook is stretched slightly, the wire rope catches on the anti-slip knob to prevent it from slipping off the hook, ensuring safe operation.



NR2 0.25t (Petit)

NICE LEVER NR2

Use it to Lift, Lower, Fasten, and pull

Use it for:

Loading a truck, centering building material at a construction site, setting up or moving machinery and other heavy objects, laying down drain pipes and hume pipes, working in narrow spaces as in shipyards and mines.

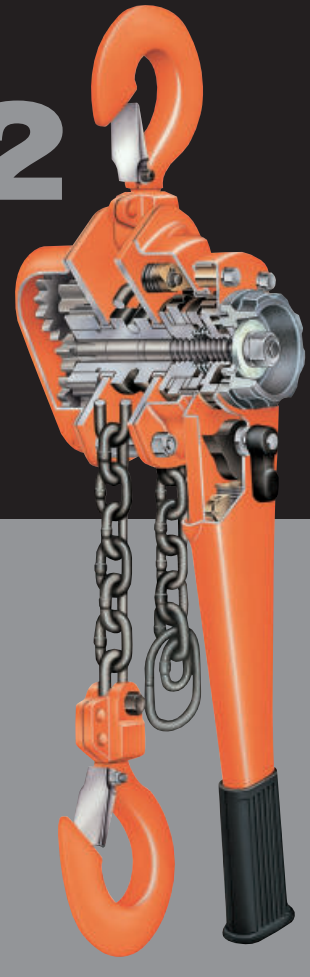

Lifting



Lowering



Fastening



Pulling



0.8~1 t



1.6 t



3.2 t



6.3 t



9 t



NR2 0.5t

Specifications

Model Number	NR2-03	NR2-05	NR2-08	NR2-10	NR2-15	NR2-30	NR2-60	NR2-90	
Capacity (t)	0.25	0.5	0.8	1	1.6	3.2	6.3	9	
Standard Lift (m)	1.0	1.5	1.5	1.5	1.5	1.5	1.5	1.5	
Net Weight (kg)	1.9	3.5	6.0	7.2	9.8	16.6	27.0	47.3	
Min. Distance between Hooks (mm)	230	260	295	325	350	425	565	660	
Pull Required to Lift Full Load	(kgf)	30	34	21	23	27	38	39	40
	(N)	294	333	206	226	265	373	382	392
Chain thickness (mm)	4.0	5.0	5.6	6.3	7.1	9.0	9.0	9.0	
Dimension	a (mm)	85	108	146	146	161	195	195	195
	b (mm)	65	82	119	126	146	180	243	318
	c (mm)	230	260	295	325	350	425	565	660
	d (mm)	151.5	267	256	256	368	368	368	368
	e (mm)	24	27	27	30	34	43	47	67

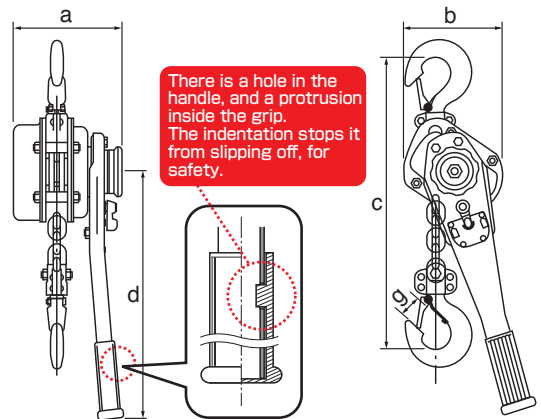

Please note that the specifications on this leaflet may be modified for improvements without notice.

Vital offers products that are designed for longtime use, providing the lowest possible per-use cost.



Since 1933
VITAL CHAIN BLOCK MFG.CO.,LTD.
<http://www.vital.co.jp>